

### Items Supplied >

- 1 – MUFFLER ASSEMBLY
- 2 – 5/16 X 1/2 FLANGED HEX BOLT
- 1 - 268-65 MUFFLER CLAMP

### Application >

HARLEY:	
STREET 500	14-20
STREET 750	14-20

**NOTE:** DOES NOT FIT STREETROD 750.

### Instruction Manual >

6510B

Page 1 of 1

#### Read all instructions carefully and completely before installing your new slip-on mufflers

1. Loosen the front and rear clamps on the catalytic converter heatshield. Remove the rear clamp and then swing the heatshield down so the muffler clamp can be accessed. See **Figure 2**.
2. Loosen the muffler clamp and remove the two bolts in the muffler bracket. Then slide the muffler backward off the headpipe.
3. Slide the supplied muffler clamp over the slip-on muffler and position it as shown in **Figure 1** with the hex head facing inward and down.
4. Slide the muffler onto the headpipe until the mounting holes align. See **Figure 2**.
5. Fasten the muffler using the supplied mounting bolts in the same manner as stock but **do not tighten**. Install the catalytic converter heatshield and verify that the gap, where the muffler meets the catalytic converter heatshield is similar to the gap the stock muffler allotted.
6. Check all the clearances and alignments then tighten the muffler clamp and catalytic converter heatshield clamps. (NOTE: The muffler clamp should be flush with the end of the muffler when tightened. See **Figure 1**. If the muffler clamp is slid forward past the slots on the muffler slip the clamp will not tighten the muffler properly). Tighten the mounting bolts to factory specifications.
7. **IMPORTANT:** Before starting your engine remove all fingerprints from all exhaust surfaces. To clean your black exhaust system use a liquid based soap detergent, such as dishwashing soap applied with a soft cloth and rinse with clean water. Note: Avoid abrasive cleaning methods such as granular or dry cleansers, simple green, scotch-brite or steel wool pads. Abrasives may breach the coating and shorten life.

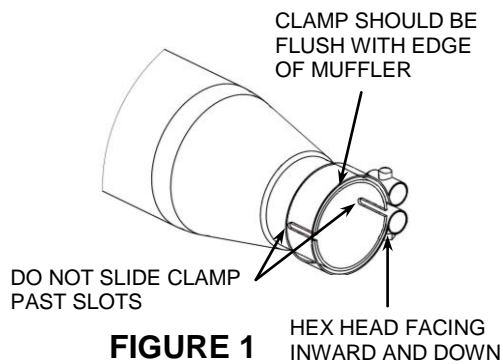

DISCLAIMER: NOT LEGAL FOR SALE OR USE IN CALIFORNIA ON ANY POLLUTION CONTROLLED MOTOR VEHICLE. THE SALE, USE, OR INSTALLATION OF THIS PRODUCT MAY ALSO BE ILLEGAL NATIONWIDE UNDER THE FEDERAL CLEAN AIR ACT (42 U.S.C. § 7522(A)(3)).