

Items Supplied >

2 – FRONT & REAR EXHAUST HEADPIPE / HEATSHIELD ASSEMBLY
1 – MUFFLER ASSEMBLY
1 – EXHAUST MOUNT BRACKET
4 – CLAMPS HS-24
2 – CLAMPS HS-28
2 – CLAMPS 27-61 MSC
2 – BOLT, HEX 5/16-18 x 5/8"
2 – BOLT, HEX 3/8 x 3/4"

Application(s) >

HARLEY ROCKER 2008-2010

Instruction Manual >

6235

Page 1 of 2

PRIOR TO INSTALLATION, MAKE SURE YOUR STOCK HEADPIPE GASKETS ARE IN GOOD SHAPE. IF YOU HAVE ANY DOUBTS AS TO THEIR CONDITION, REPLACE THEM.

Read all instructions carefully and completely before installing your new exhaust system

1. Unbolt the seat and remove the plastic battery cover. Disconnect the positive and negative battery terminals and remove battery from motorcycle.
2. To remove the rear O2 sensor remove the plastic push rivet located under the battery. See Figure 1. This will release the O2 sensor connector under the oil tank. Unplug the factory O2 connector from wiring harness.
3. On the front of the motorcycle remove the 2 Allen bolts that secure the voltage regulator bracket to the frame, and remove the rectangular cover over the top of this bracket. Ease the voltage regulator forward just enough to unplug the front O2 connector.
4. Remove stock exhaust system. Retain the stock 5/16" flange nuts for use later during reassembly.
5. Remove the flanges, retaining rings and O2 sensors from the stock headpipes.
6. Remove the passenger footpegs. (Cobra offers a passenger footpeg relocation kit: Part #606-6235. Contact supplier or go to www.cobrausa-hd.com for more information.)
7. Place the exhaust mount bracket on the motorcycle and bolt into place using the supplied 3/8" bolts. See Figure 2. **DO NOT FULLY TIGHTEN.**
8. Remove the front and rear headpipes from box and install stock flanges, retaining rings and O2 sensors onto pipes.
9. Install the front and rear headpipes on the motorcycle using the stock 5/16" flange nuts but do not tighten. Make sure the pipes are parallel with each other.
10. Remove the muffler assembly from the box and slide one supplied T-clamp #27-61MSC onto each muffler tube. Refer to Figure 3 for proper alignment.

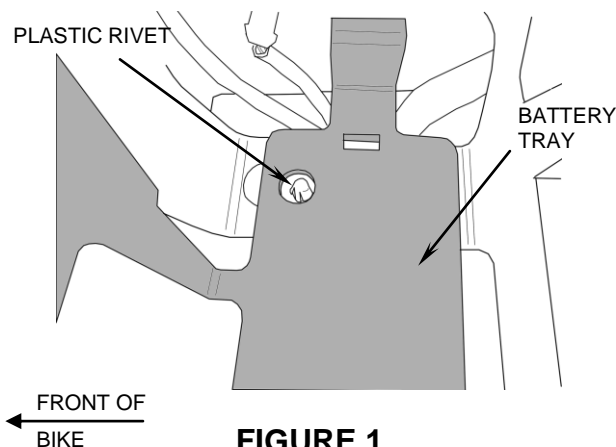
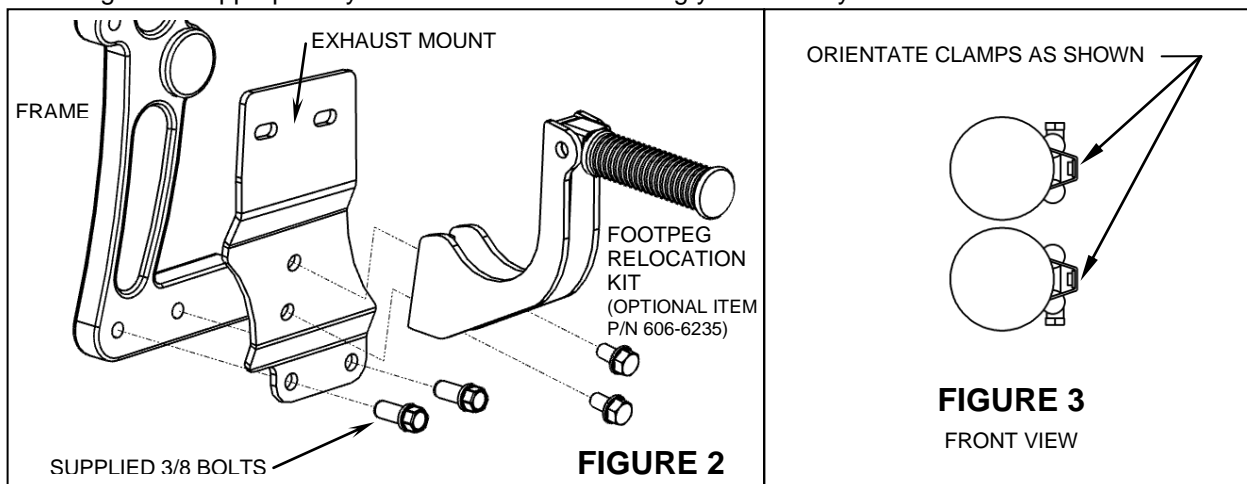

FIGURE 1

*** Cobra® recommends you always wear a helmet while riding. Please never operate your motorcycle while under the influence of alcohol and/or drugs. Enjoy the new look of your motorcycle and please ride safely.**

9. Slide the muffler assembly onto the head pipes by tapping on the head pipes with your hand as you push the muffler forward making sure the assembly slides as far forward as possible. Secure the muffler assembly to the mounting bracket using the supplied 5/16 bolts but **do not tighten**.
10. Make sure the muffler assembly is parallel with the head pipes (this is critical) then tighten the following in order, muffler bracket to the frame, muffler assembly to the muffler bracket, head pipe flanges to the motor (slowly tighten opposing nut) and muffler clamps. (NOTE: If the muffler clamps are slid to far up the muffler or past the two slots, the clamps will not tighten.)
11. Plug the rear O₂ sensors back into motorcycle wire harness and reinstall the plastic push rivet removed in Step 2 into the original location. Reinstall front O₂ connector then tighten voltage regulator bracket bolts to factory specifications.
12. Unscrew the remaining hose clamps and feed the tail end of the clamp through the clips on the inside of the heat shields. The screw end of the hose clamp should be accessible for tightening but not visible when the heat shields are mounted to the pipes. The larger HS-28 clamps go to the rear of the heatshields over the muffler bodies.
13. To install the front heatshield, first slide the rear portion of the heatshield over the muffler, continue to slowly slide it forward pushing the front of the shield gently into place between the frame and motor (Hint: Spread the hose clamps apart slightly to make it easier to slide them over the muffler assembly and head pipes). Make sure the muffler clamps don't interfere with the heatshields and are aligned as shown in Figure 3. Snug the heatshield clamps but do not tighten.
14. Install the rear heatshield the same way as the front heatshield. Tighten all clamps on both heatshields.
15. Make sure all the hardware (brackets, headpipes, heatshields, mufflers and baffles) have been tightened appropriately and cleaned before starting your motorcycle.



IMPORTANT: Your motorcycle is equipped with fuel injection; it is recommended that you install a Cobra Fi2000® Digital Fuel Processor with your Cobra exhaust system. **Cobra Part #: 692-1611CL.** Cobra is not responsible for the performance of any other fuel management system used with Cobra exhaust systems.

- * **Before starting your engine remove all fingerprints from chrome with a quality wax or chrome polish. Failure to do so can cause discoloration. Due to fluctuations in fuel injection/carburetion settings, timing, etc., Cobra Engineering does not warrant against chrome discoloration.**

California does not allow the use of aftermarket exhaust systems that remove original equipment catalyts, (except for racing use only) unless the Air Resources Board has issued an Executive Order for that system.