

## Items Supplied >

- 1 – RIGHT MUFFLER ASSEMBLY
- 1 – LEFT MUFFLER ASSEMBLY

## Application >

HARLEY:  
DRESSER 17-20

## Instruction Manual >

6071

Page 1 of 1

### Read all instructions carefully and completely before installing your new slip-on mufflers

1. Remove the saddlebags carefully.
2. Remove and save the mounting hardware securing the mufflers to the brackets. Loosen the stock muffler clamps then pull the stock mufflers free from the head pipes. Save the stock clamps because they will be reused.
3. Position the stock clamps with the hex head facing the ground as shown in **Figure 1** and slide them onto the slip-on mufflers.
4. Slide the mufflers onto the head pipes (Cobra logo facing outward) until the mounting holes align.
5. Fasten the mufflers using the stock mounting hardware in the same manner as stock but **do not tighten**. Verify that the gap, where the mufflers meet the stock heat shields, is similar to the gap the stock mufflers allotted.
6. Check all clearances and alignments then tighten the clamps. (NOTE: The muffler clamps should be flush with the end of the muffler when tightened. See **Figure 2**. If the muffler clamps are slid forward past the slots on the slip collar the clamps will not tighten the mufflers properly. Also, make sure the clamp spacer is not over the slots. The slots need to be covered by the clamp band so that it seals the slots properly. Rotate the clamp if necessary).
7. Tighten the mounting bolts to factory specifications.
8. Reinstall saddlebags carefully.
9. **IMPORTANT: Before starting your engine remove all fingerprints from chrome with a quality wax or chrome polish. Failure to do so can cause discoloration. Due to fluctuations in fuel delivery settings, timing, etc., Cobra Engineering does not warrant against chrome discoloration.**

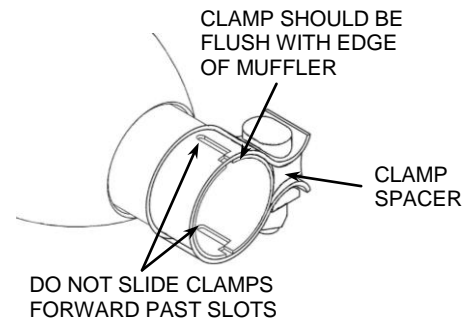
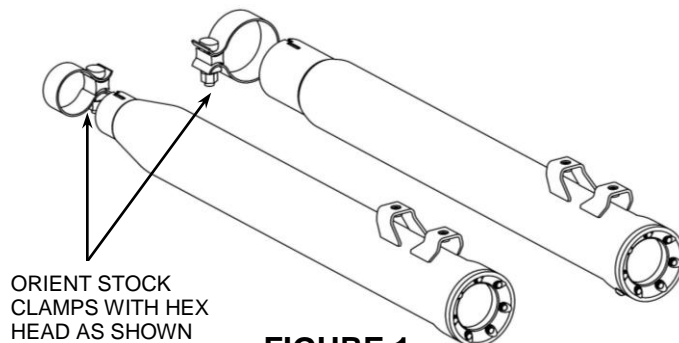

POSITION OF MUFFLERS AND MOUNTING BRACKETS SHOWN ABOVE MAY VARY FROM ACTUAL APPLICATION

REPLACEMENT E-GLASS PACKING AND OPTIONAL 1 $\frac{3}{4}$ " QUIET CORES CAN BE PURCHASED THROUGH YOUR DEALER OR ONLINE AT [WWW.COBRAUSA.COM](http://WWW.COBRAUSA.COM)

**DISCLAIMER: NOT LEGAL FOR SALE OR USE IN CALIFORNIA ON ANY POLLUTION CONTROLLED MOTOR VEHICLES.**