



Items Supplied >

- 1 – INTAKE COVER W/ SCREEN/RING ASSEMBLY
- 1 – VENTURI AIR FILTER
- 1 – MOUNTING PLATE
- 1 – BILLET VELOCITY STACK
- 1 – THROTTLE BODY COVER
- 2 – INTAKE GASKET
- 2 – BREATHER BOLT, 3/8"-16 X 1" W/ TEFLON SEALANT
- 3 – BOLT, 1/4"-20 X 1-1/8", BUTTONHEAD W/ LOCK PATCH
- 3 – LOCK WASHER, 1/4" TOOTHED
- 5 – BOLT, 1/4"-20 X 1/2", BUTTONHEAD W/ LOCK PATCH

Application(s) >

HARLEY:  
 DRESSER 17-20  
 21-22\*

\* NOTE: SEE EMISSIONS STATEMENT ON PG. 3  
 NOTE: DOES NOT FIT CVO MODELS.

Instruction Manual >

606-0101- 01/02/03/04 -SB

Page 1 of 3

Read all instructions carefully and completely before installing your new air intake.

1. Remove the allen bolt from the center of the stock air cleaner and remove the cover. Remove the (3) bolts securing the filter to the throttle body and remove the filter and breather hose assembly. Save the stock breather hose assembly as this will be reused. Remove the two breather bolts from the cylinders and remove the back cover.
2. Install the supplied breather bolts into the cylinders. See **FIGURE 1**. Tighten securely.
3. Insert the center hose of the stock breather hose assembly through the hole in the supplied mounting plate and then through the velocity stack so that the hose is in the center of the velocity stack. See **FIGURE 1 & 2**.
4. While holding that assembly together with one hand, Insert the (3) supplied 1/4"-20 x 1-1/8" buttonhead bolts and lock washers through the mounting holes in the velocity stack and mounting plate. See **FIGURE 1**.
5. Then align the supplied gaskets and spacer so the notch is to the bottom left and slide them over the (3) bolts onto the backside of the mounting plate. Make sure there is a gasket on both sides of the spacer. See **FIGURE 1**.
6. Align all the components with the throttle body and start threading the (3) buttonhead bolts into the throttle body. Tighten the three bolts evenly making sure the inner diameter of the velocity stack, gaskets, and spacer align with the inner diameter of the throttle body.
7. Attach the stock breather hoses to the breather bolts in the cylinder head. The front hose has to go behind the mounting plate to be attached to the breather bolt.
8. Install the throttle body cover using the (2) 1/4-20 X 1/2" button head screws as shown in **FIGURE 1 & 2**.
9. Place the supplied venturi filter onto the velocity stack. See **FIGURE 3**.
10. Insert the intake screen into the intake ring so the screen sits inside the edge of the ring. See **FIGURE 3**.
11. Place the ring and screen between the legs of the intake cover as shown in **FIGURE 3**.
12. Place the intake cover, ring, and screen assembled in previous step over the air filter and align each leg to the base mounting plate threaded holes. Be sure screen sits at a 45° angle to the bottom leg, and C/V logo'd leg is at the upper left position. See **FIGURE 3**.
13. Insert the (3) supplied 1/4"-20 x 1/2" buttonhead bolts through the intake cover and into the base mounting plate, see **FIGURE 3**. Double check all parts are aligned properly and tighten securely.
14. Verify all the bolts are tight and then wipe off any fingerprints with a clean microfiber cloth.

CONTINUED ON PAGE 2

QUALIFIED MANUFACTURER DECLARED U.S. 50-STATE LEGAL EMISSIONS  
 REPLACEMENT PART ON ALL 2017-2020 HARLEY-DAVIDSON® FL TOURING MODELS

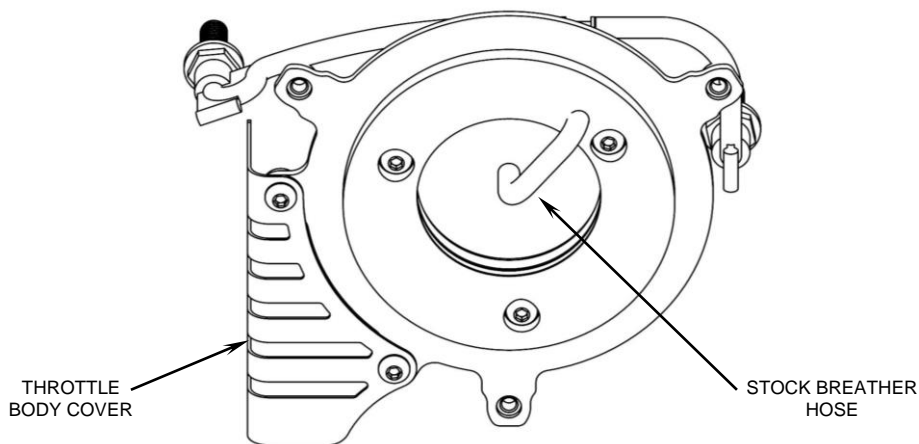
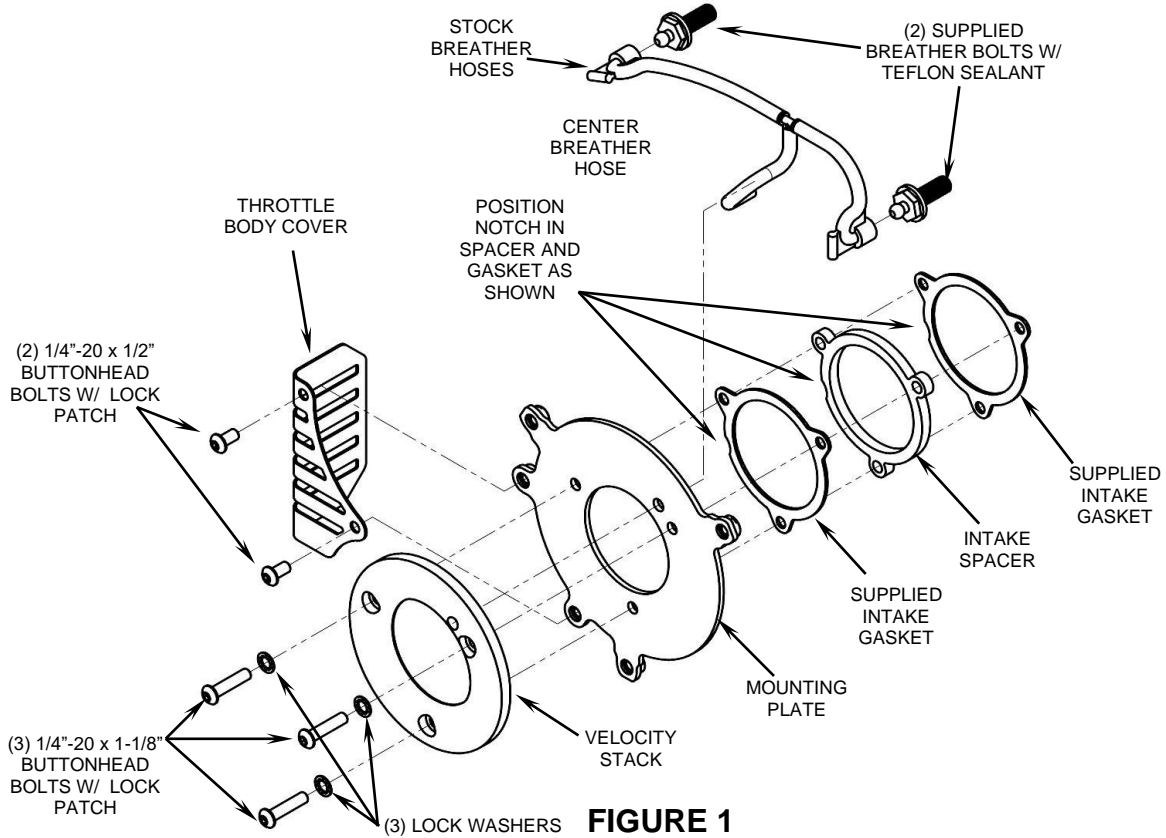

CONTINUED ON PAGE 3

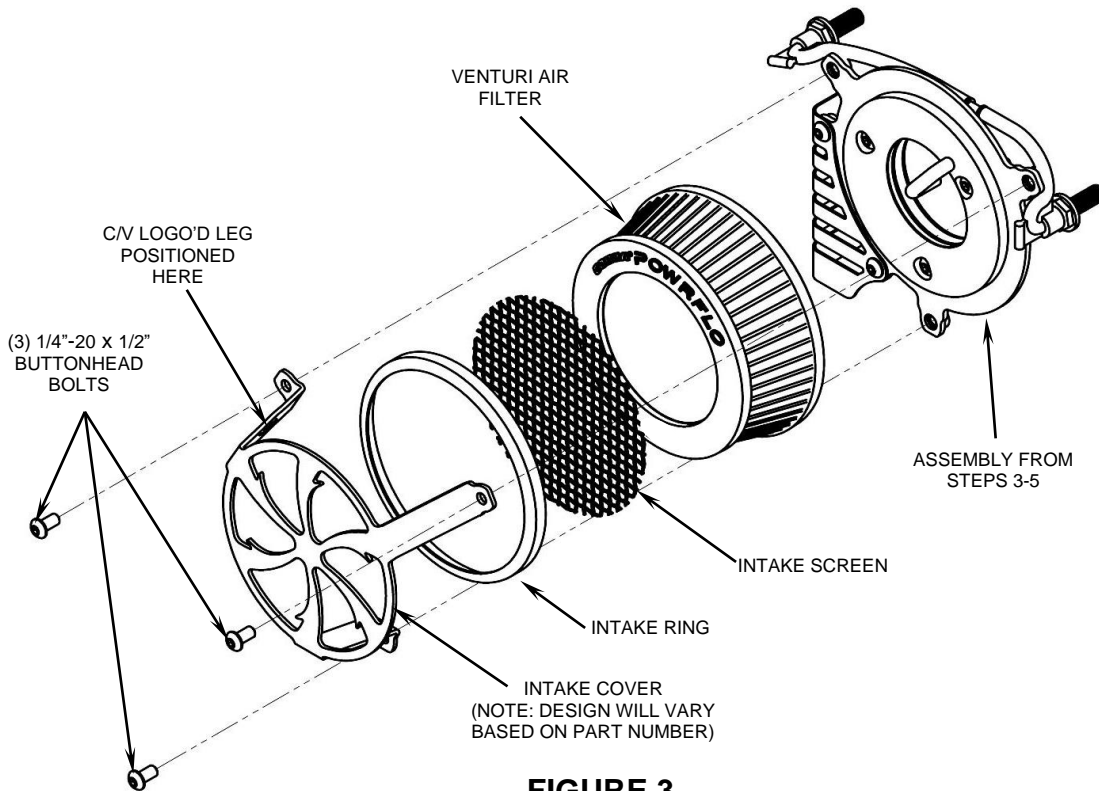

\*FOR MODEL YEARS 2021-2022:

**DISCLAIMER: NOT LEGAL FOR SALE OR USE IN CALIFORNIA ON ANY POLLUTION CONTROLLED MOTOR VEHICLE. THE SALE, USE, OR INSTALLATION OF THIS PRODUCT MAY ALSO BE ILLEGAL NATIONWIDE UNDER THE FEDERAL CLEAN AIR ACT (42 U.S.C. § 7522(A)(3)).**

**QUALIFIED MANUFACTURER DECLARED U.S. 50-STATE LEGAL EMISSIONS REPLACEMENT PART ON ALL 2017-2020 HARLEY-DAVIDSON® FL TOURING MODELS**

DOCUMENT NO. 0018 REV. B