

Items Supplied >

- 1 - Sissy Bar with Pad and Insert
- 2 - Detachable Side Plates (Left/Right) Chrome or Black
- 2 - 3/8" I.D. Front, Mount Bushing Chrome or Black
- 2 - 3/8" I.D. Rear, Outer/Inner/Plastic Bushing Black
- 4 - 3/8"-16 x 3.0" Sockethead Screws Zinc
- 4 - 3/8" Flat Washers
- 4 - M8 x 20mm Buttonhead Screws

Application(s) >

HARLEY:		
SOFTAIL:	FLHC	18-20
	FLHCS	18-20

Instruction Manual >

602-2010 / 602-2010B

Page 1 of 3

Read all instructions carefully before installing your new Cobra® product!

1. Prepare a large towel or moving blanket to set the removed saddlebags on. Start on the right side of the motorcycle. Open the saddlebag lid, **Figure 1**. The screws and spacers are retained with the bag by an o-ring on the inner-side of the spacer on the screw, when the screws are fully loose the bag will be pulled off the motorcycle with the screws and spacers. Have an assistant hold the bag as you loosen the front and rear screws retaining the saddlebag and spacers. Carefully pull the bag off the front lower mount and set down on towel. **NOTE:** Remove only one set of screws right to left on the motorcycle at a time so the saddlebags or fender do not fall resulting in possible scratches or damage to the fender, exhaust, saddlebag or paint.
2. Remove the o-rings from the front and rear screws and remove the stock inner spacers (the one closer to the fender rail), and stock bolts from the saddlebags. Insert (1) of the supplied 3/8-16 X 3.0" screws through (1) supplied 3/8" washer, the front saddlebag mount hole and the supplied front backrest bushing, see **Figure 2**. Insert (1) of the supplied 3/8-16 X 3.0" screws through (1) supplied 3/8" washer, the rear saddlebag mount hole and the supplied rear backrest bushing. Place sufficient blue loctite on both screws. Do not install original o-rings. Reinstall the right bag carefully on to the lower front mount and then thread in the new screws being sure the spacers are in place correctly and centered in the fender rail. Snug the bolts but do not fully tighten at this time.

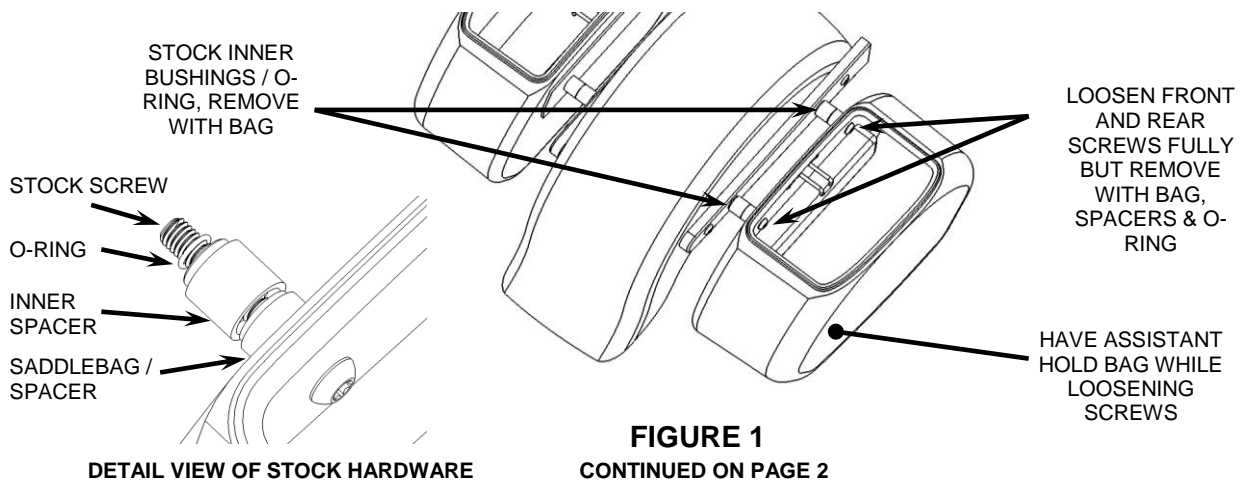

* Cobra® recommends you always wear a helmet while riding. Please never operate your motorcycle while under the influence of alcohol and/or drugs. Enjoy the new look of your motorcycle and please ride safely.

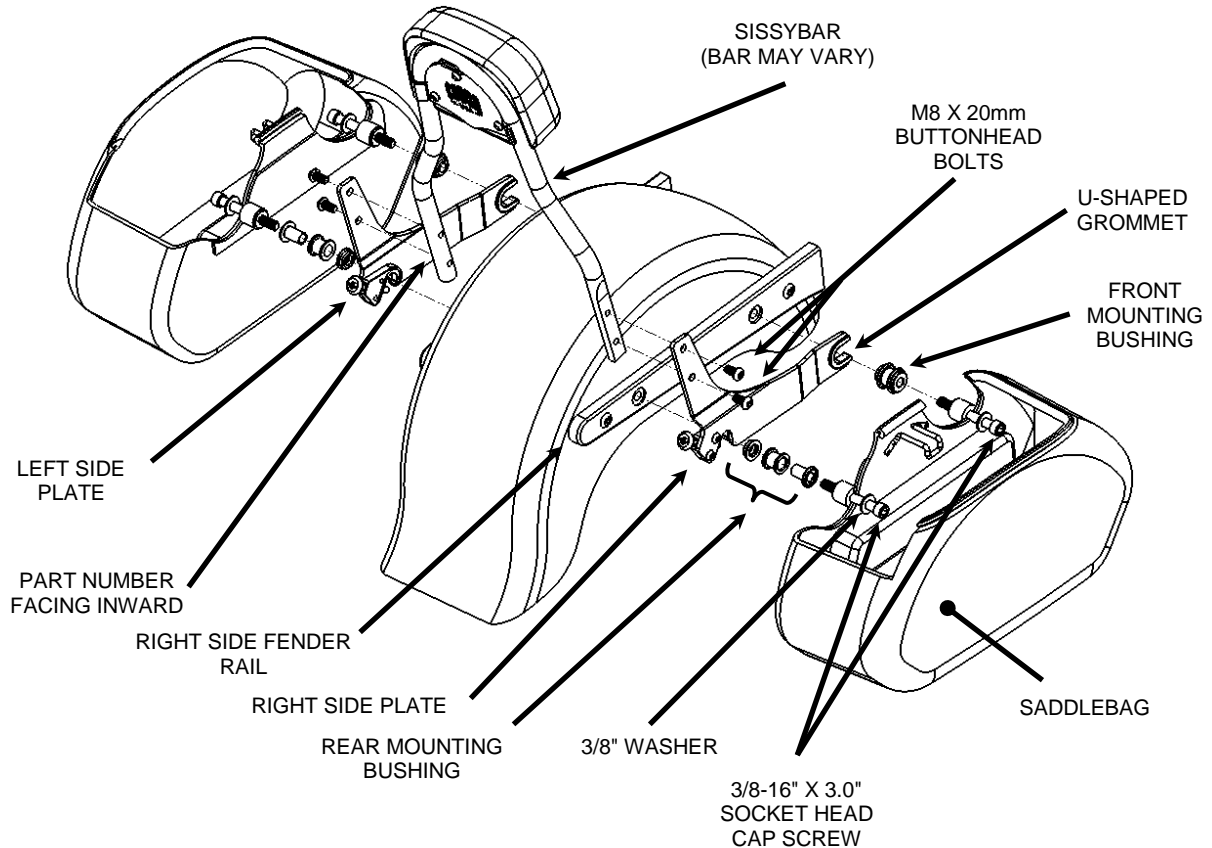

FIGURE 2

3. Repeat, Steps 1 and 2 for left side saddlebag using **Figure 2**, be sure to orientate all parts correctly.
4. Install the supplied side plates on to the sissy bar with the four M8 X 20mm button head bolts. Make sure the u-shaped grommets are facing the same direction as the sissy bar pad, (forward) and the part numbers are facing inward on the left and right side toward the motorcycle fender rails. See **Figure 2**. Snug the bolts but **DO NOT TIGHTEN** at this time.
5. Install the assembled sissybar with the u-shaped grommets over the front mount bushings mounted in Steps 2 & 3. Once the bar is on the front bushings, push forward on the bar firmly from the rear of the motorcycle to seat the grommets fully in the side plates and on the bushings, **Figure 3**.

CONTINUED ON PAGE 3

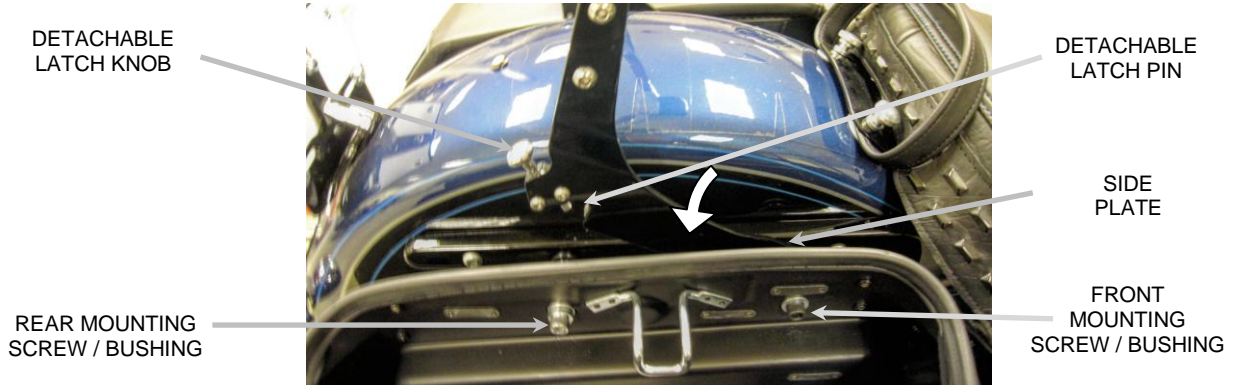

FIGURE 3

6. Pull backward on both detachable latch knobs and then push downward on the backrest to allow the backrest to sit completely on the rear mounting bushings. Then release the detachable latch knob to fully engage the latch pin underneath the mounting kit bushing. See **Figure 4**.
7. Always check to make sure both detachable latch pins are fully engaged on the bottom of the mounting kit bushing. Failure to fully engage the detachable latch pin could cause the backrest to come loose while riding. See **Figure 4**.
8. Pull backward on the top of the sissy bar and then tighten all four M8 X 20mm bolts. See **Figure 4**.
9. Tighten all (4) of the 3/8-16 X 3.0" long Socket head cap screws attaching the saddlebags and bushings to the fender rails. Tighten to factory torque specifications, see **Figure 4**.
9. Before each ride, check to make sure the detachable latches are fully engaged underneath the mounting bushings.
10. Check the tightness of all the screws after the first ride, after the first 500 miles and during each engine service.

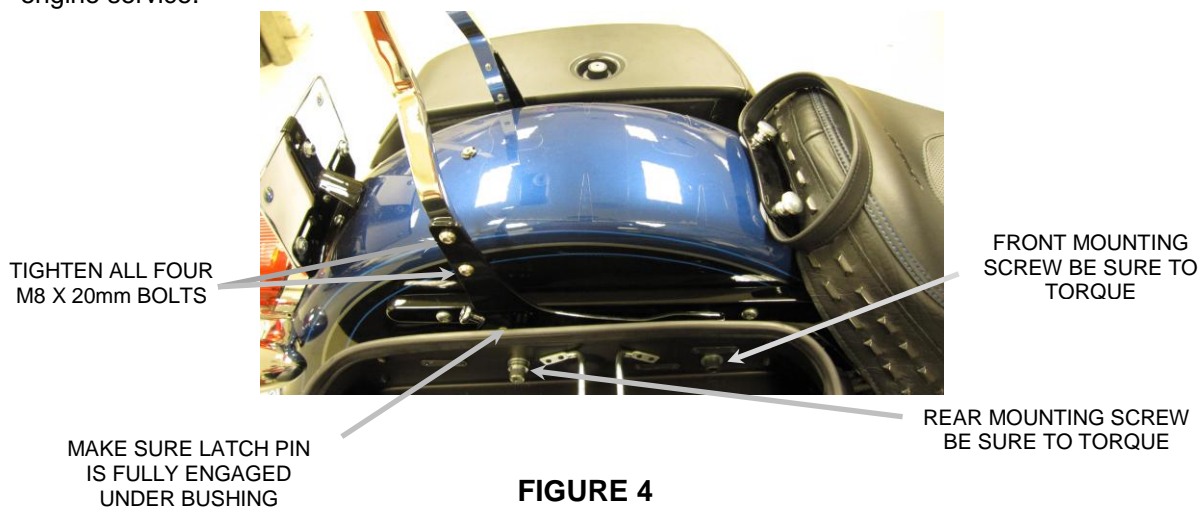

FIGURE 4

To clean your black accessory use a liquid based soap detergent, such as dishwashing soap applied with a soft cloth and rinse with clean water. Note: Avoid abrasive cleaning methods such as granular or dry cleansers, simple green, Scotch-Brite or steel wool pads. Abrasives may breach the coating and shorten life.