

## Items Supplied >

1 – FRONT EXHAUST W/HEATSHIELD  
1 – REAR EXHAUST W/HEATSHIELD  
1 – MUFFLER ASSEMBLY  
1 – EXHAUST BRACKET  
1 – EXHAUST SUPPORT BRACKET  
2 – EXHAUST FLANGES  
7 – HOSE CLAMPS  
2 – CLAMP, 27-61MSC  
3 – BOLT, HEX 5/16-18 x 5/8  
2 – SCREW, BUTTON ¼-20 x 3/8  
2 – BILLET MUFFLER TIPS

## Application(s) >

YAMAHA STRATOLINER 2006 - 2013

## Instruction Manual >

2924

Page 1 of 3

**PRIOR TO INSTALLATION, MAKE SURE YOUR STOCK HEADPIPE GASKETS ARE IN GOOD SHAPE. IF YOU HAVE ANY DOUBTS AS TO THEIR CONDITION, REPLACE THEM.**

**Read all instructions carefully and completely before installing your new exhaust system**

1. Loosen and move the right side floorboard out of the way to ease installation of the exhaust.
2. Perform the following to remove the stock exhaust system. **NOTE:** You must disconnect and remove the power valve cables as well as unplug the oxygen sensor connector first, then remove the exhaust system and mounting bracket, see **Figure 1** for power valve. Loosening the jam nuts on each cable, and disengaging the cable barrels from the power valve pulley disconnect the power valve cables. The power valve, and cables are not needed with the new Cobra exhaust system, leave the solenoid box under the seat in place without the cables. To disconnect the O<sub>2</sub> sensor remove the right rear footpeg and remove the steel plate with hook securing O<sub>2</sub> sensor harness behind it, retain plate for later reinstallation. Remove the socket head screw securing the O<sub>2</sub> sensor harness and bracket to engine case on the right side of the motorcycle, see **Figure 2**, unplug the stock male and female connectors, and remove entire exhaust system. Disengage the female O<sub>2</sub> connector from the small bracket, (which was unbolted from engine case), to gain extra harness length, upon reassembly of new Cobra exhaust, the small bracket, (from engine case), will not be reused, **unless** a closed loop Fi2000® (92-1773CL /92-1773CL-50), is to be used, then please refer to those specific instructions. Next remove the oxygen sensor from the stock exhaust and retain for later reinstallation.
3. Install new exhaust-mounting bracket using the stock M10 bolts; tighten to factory specifications, Figure 3.
4. Install the front and rear headpipes on to the motorcycle using the supplied flanges, stock bolts and nuts. **NOTE:** On the rear headpipe be sure to install the stock flange cover as shown in Figure 4. Make sure the pipes are parallel to each other. **DO NOT TIGHTEN.**
5. Remove the muffler assembly from the box and slide two supplied 27-61MSC clamps onto the muffler inlets, refer to Figure 5 for alignment. Do not install oxygen sensor at this time, as it will not clear the frame rail during installation of the muffler assembly.
6. Slide the muffler assembly on to the headpipes by tapping on the headpipes by hand as you push the muffler forward making sure the assembly slides as far forward as possible. Secure the muffler assembly to the mounting bracket using the supplied 5/16-18 bolts but **DO NOT TIGHTEN.** Install the oxygen sensor at this time, by inserting it between the right frame rail, and engine case, tighten securely once installed.
7. Reconnect the oxygen sensor connectors, then reposition behind the frame rail and reinstall the M6 x 50 mm bolt removed from engine case and tighten to proper factory torque specification.

**\* Cobra® recommends you always wear a helmet while riding. Please never operate your motorcycle while under the influence of alcohol and/or drugs. Enjoy the new look of your motorcycle and please ride safely.**

8. Reinstall the right rear footpeg, be sure to reinstall the small steel plate with hook welded to it, to retain heatshield between transmission case and swing arm. Do not try to reinstall oxygen sensor harness to hook on plate, **unless** a closed loop Fi2000® is used to extend oxygen sensor harness length.
9. Remove M8 bolt and nut from lower right side saddlebag support. Install supplied exhaust support to muffler body with supplied 5/16" flange bolt, **DO NOT TIGHTEN**. Insert M8 bolt removed earlier in this step through the top of the saddlebag support, exhaust support and start locknut, Figure 6.
10. Make sure the muffler assembly is parallel to the ground (this is critical) then tighten the following in order, muffler assembly to the muffler bracket, headpipe flanges to the motor (slowly tighten opposing nut), rear exhaust support bracket to saddlebag mount, muffler clamps. (NOTE: If the muffler clamps are slid to far up the muffler or past the three slots, the clamps will not tighten.)
11. Unscrew the remaining hose clamps and feed the tail end of the clamp through the clips on the inside of the heatshields. The larger clamps are to be placed at the rear of the heatshield so they clamp over the muffler assembly. The screw end of the hose clamps should be accessible for tightening but not visible when the heatshields are mounted to the pipes.
12. To install the front heatshield, first slide the rear portion of the heatshield over the muffler, continue to slowly slide it forward pushing the front of the shield gently into place between the frame and motor (Hint: Spread the hose clamps apart slightly to make it easier to slide them over the muffler assembly and headpipes). Make sure the muffler clamps do not interfere with the heatshields and are aligned vertically as shown in Figure 5. Snug the heatshield clamps but **DO NOT TIGHTEN**.
13. Install the rear heatshield the same way as the front heatshield.
14. Install one billet tip on each heatshield making sure the angled ends of the tips are parallel with each other. Fasten the tips with the supplied ¼-20 screws making sure they snug up against the heatshield leaving no gap between the tip and heatshield when tightened. **If it is difficult to slide the tips into the heatshields, loosen the clamps on the heatshield, failure to do this may cause damage to the chrome tips.**
15. Tighten the clamps on the heatshields.
16. Retighten the floorboard mount loosened in Step 1 to factory specifications.
17. Make sure all the hardware (brackets, headpipes, heatshields, mufflers and baffles) has been tightened appropriately and cleaned before starting your motorcycle.

**IMPORTANT:** Cobra highly recommends using a Fi2000® Fuel Management System to help eliminate lean conditions and popping sounds. (Cobra Part# **92-1773AT** & **92-1773CL** for 49 state models and Part# **92-1773CL-50** for CA state models.)

**Before starting your engine remove all fingerprints from chrome with a quality wax or chrome polish. Failure to do so can cause discoloration. Due to fluctuations in carburetor settings, timing, etc., Cobra Engineering does not warrant against chrome discoloration.**

California does not allow the use of aftermarket exhaust systems that remove original equipment catalysts, (except for racing use only) unless the Air Resources Board has issued an Executive Order for that system.

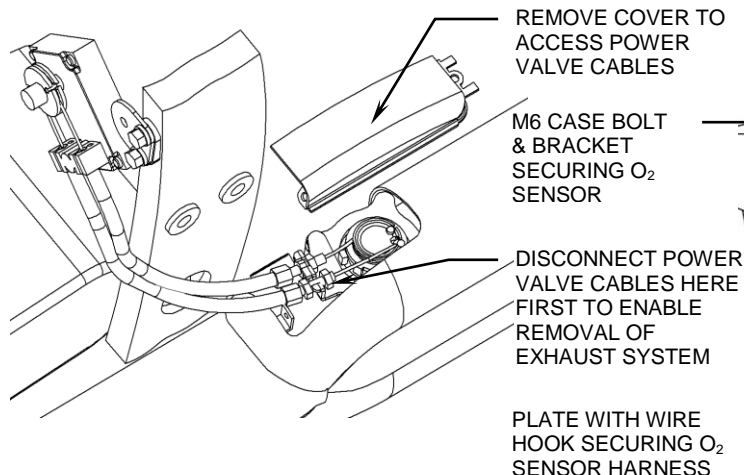

FIGURE 1

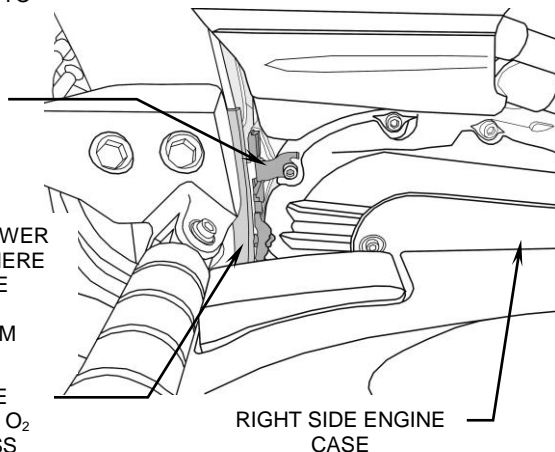

FIGURE 2

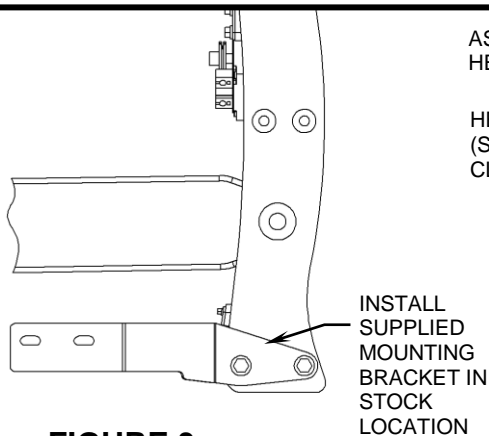

FIGURE 3

ASSEMBLY ORDER OF REAR EXHAUST HEADPIPE AND COMPONENTS:

HEADPIPE COLLAR, (SHORTENED FOR CLARITY)

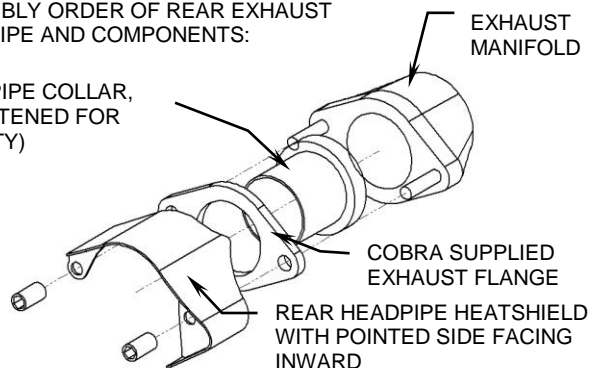

FIGURE 4

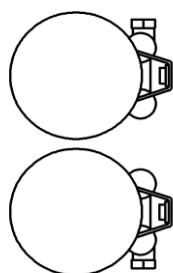

FIGURE 5

HEAT SHIELD CLAMPS ALIGNED VERTICALLY TO EACH OTHER

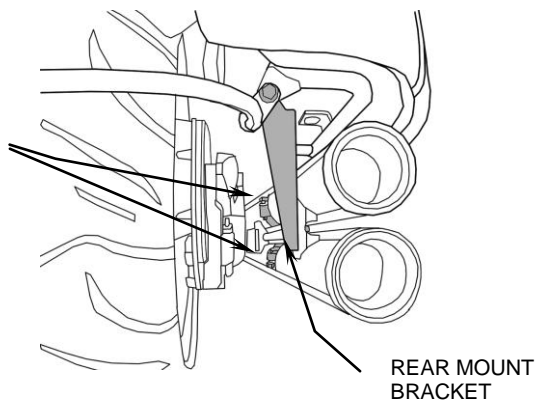

FIGURE 6