

**Items Supplied >**

- 1 – Powrpro Black Fuel Injection Module
- 5 – Zip Ties 6"
- 1 – Velcro Stripe

**Application(s) >**

HARLEY DYNA 2006

**Instruction Manual >**

692-1609B

Page 1 of 3

**Read all instructions carefully and completely before installing your new POWRPRO module. It is recommended that a qualified mechanic or technician install this product.**

1. Remove the seat and air cleaner assembly, remove both front and rear gas tank mounting bolts. Prop the rear of the gas tank up approximately 2".
2. Locate the factory connector on each fuel injector. Depress the clip on the connector and pull the connector free and move it out of the way. **Note:** A pair of needle nose pliers and a long flat blade screwdriver helps with this job. If you need additional access to the fuel injector connectors, you can remove the Idle Air solenoid by removing the two 5/16" bolts holding it on and loosening the Torx #20 screw on throttle cable bracket. Make sure to use thread-locking compound when refitting the two 5/16" bolts and correctly position the o-ring when reattaching.
3. Lay the Fi2000 module in the area underneath the seat, do not attach it to the motorcycle, route the fuel injector harness forward up the left side of the frame using the plastic harness protector and across to the right side just ahead of the rear cylinder head, See Figure 1. Route the forward set of connectors under the upper motor mount.
4. Attach on pair of the Fi2000 module's injector plugs to the front injector. Take the original HD connector and insert the corresponding Fi2000 connector into it, refer to Figure 2.
5. Attach the Fi2000 module's remaining injector plug onto the rear injector. Then take the original HD connector and insert the corresponding Fi2000 connector into it, refer to Figure 2.
6. Remove the right hand battery cover, route the black ground wire from the Fi2000 through the gap just under the frame and to the rear of the battery box. Attach the ring terminal to the negative post of the battery.
7. It is now time to install the oxygen sensor harnesses. Cut the factory zip-tie holding the rear fender wire harness to the ECU bracket and pull that harness up and out of the way, see Figure 1. Reach down and pull the remaining wiring up and out of the space between the battery box on the right and the ECU electrical box on the left. Feed the longer of the two oxygen sensor harnesses down between the rear fender and the frame. Pull the harness from underneath and route it just ahead of the swingarm, then down just behind the rear master cylinder so that the harness ends up coming out at the bottom of the bike. Route the O<sub>2</sub> sensor harness forward along the right frame rail and stock harness with the Fi2000 O<sub>2</sub> connectors ending up by the front of the engine.
8. Ziptie the O<sub>2</sub> sensor harness to the main wire harness on the frame rail.

**DISCLAIMER: NOT LEGAL FOR SALE OR USE IN CALIFORNIA ON ANY POLLUTION CONTROLLED MOTOR VEHICLES.**

9. Remove the two Allen bolts holding the voltage regulator onto the lower front frame, see Figure 3. Let it drop down, then directly behind that is a black plastic panel. Hinge that panel down to access the plugs behind it. Locate the front oxygen sensor connection, slide it off its holding pin and unplug the connector. Plug the Fi2000 O<sub>2</sub> sensor harness male connector into the O<sub>2</sub> sensor female connector and slide them back onto stock plastic panel location. Mate the stock male harness connector with the female Fi2000 connector, double up any slack and secure with zip ties to rightside framerrail. Reinstall the panel and the voltage regulator.
10. Locate the black waterproof connector in the wire harness bundle that was tucked down into the open area under the seat, see Figure 1. Unplug the female connector that comes from the rear oxygen sensor, and mate it with the male connector from the shorter Fi2000 O<sub>2</sub> sensor harness. Mate the stock male connector with the female Fi2000 connector.
11. Verify that the module has power and connections have been made correctly; watch the clear window on the FI housing and turn "ON" the key ignition and set the handlebar run switch to "ON", confirm that the Red LED turns on. On some models the Red light will turn off after 4-5 seconds as the fuel pump cycles off, which is OK. If you do not see a Red light, it may be necessary to wait for the alarm to reset (if applicable) and try again. Also confirm the side stand is up, bike is in neutral, and clutch is in. Start the bike and confirm the LED remains on solid Red. **NOTE:** Make sure ignition is turned off before attempting to change any Fi2000 harness connections if no Red light is seen. For access to the Blue Tooth Tuning App on the module, please download the PowrPro Black App to your smart device, Android 4.3 & later or Apple iOS 5.0 & later operating systems. Once the app is installed, make sure the motorcycle is in neutral and start the engine, use the connect button within the app and the Blue light on the Fi module window will light up during pairing connection and remain solid Blue while paired and connected with respective Android or Apple Device. Once the app has been used and settings saved and disconnected through the app, the Blue light will turn off, and the PowrPro Black will be ready for continued service on the motorcycle.
12. Remove the backing from the Velcro and attach the Velcro pad down between the back of the battery and the ECU on the flat area of the frame. Apply the mating Velcro to the back of the Fi2000 and attach, see Figure 1. Replace the rear fender wire harness above the Fi2000.
13. Re-install the seat, air cleaner assembly and gas tank mounting bolts.

## TROUBLE SHOOTING

If you have any problems refer to Step 11 in the main body of the instructions.

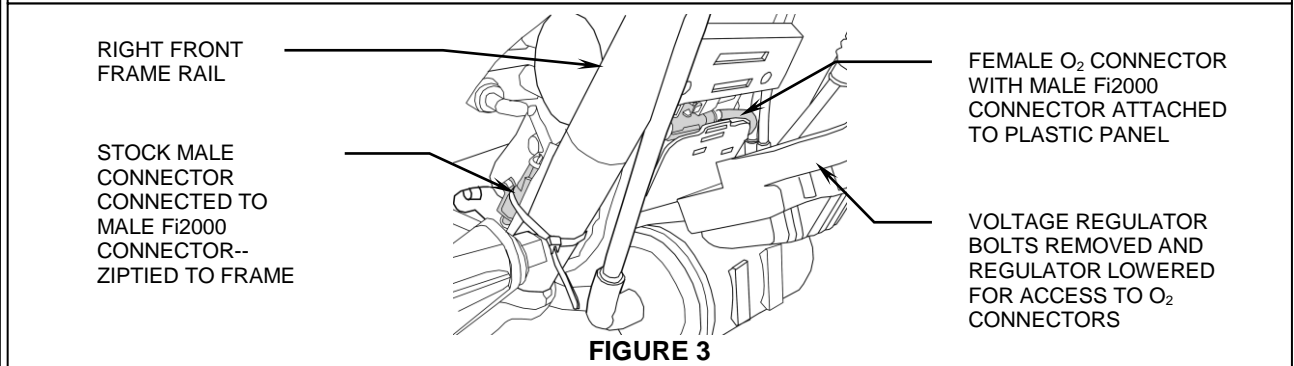
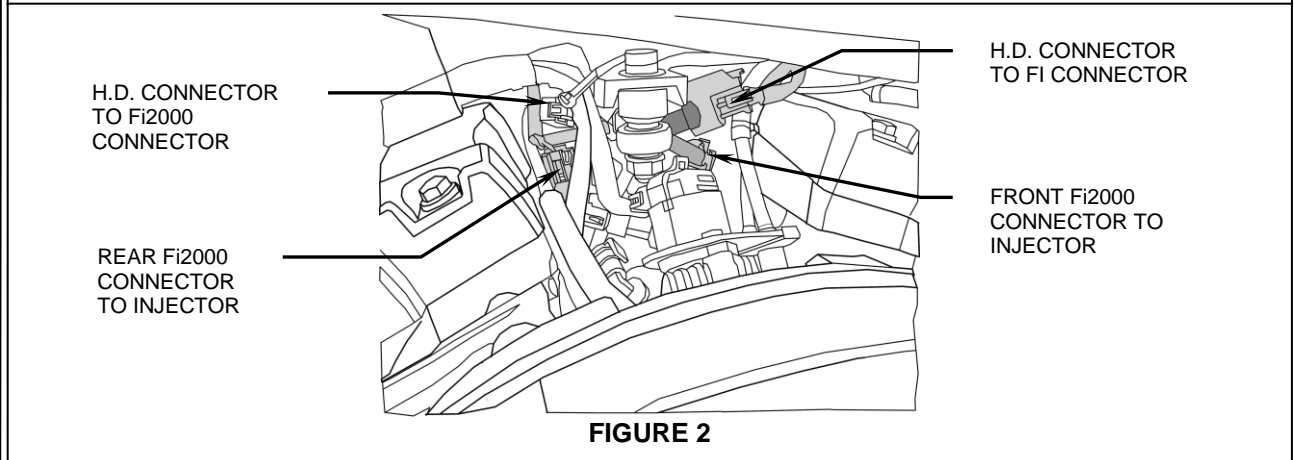
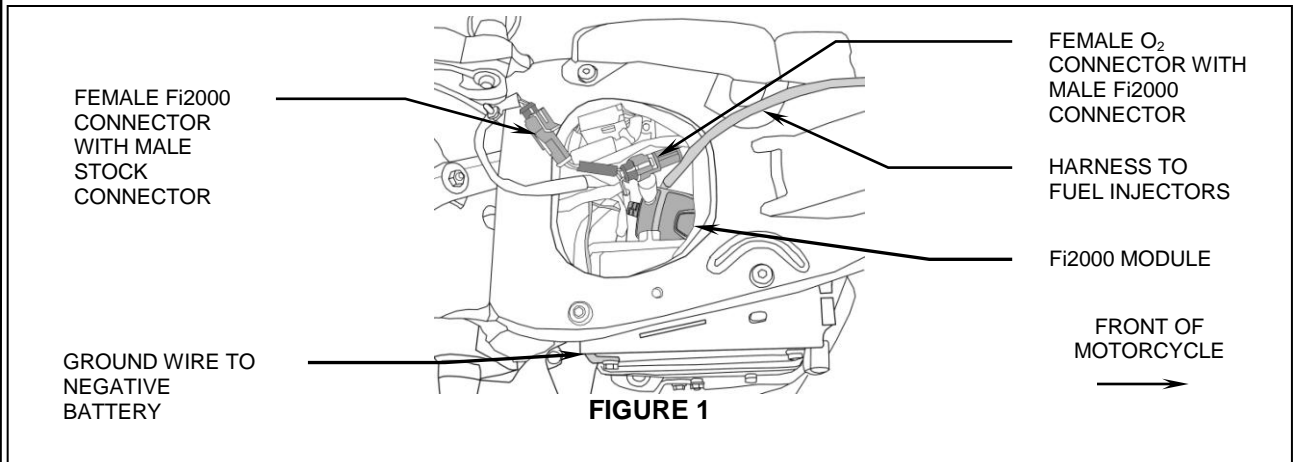

**DISCLAIMER:** NOT LEGAL FOR SALE OR USE IN CALIFORNIA ON ANY POLLUTION CONTROLLED MOTOR VEHICLES.