

## Items Supplied >

- 1 – FREEWAYBAR
- 2 – BOLT, BUTTONHEAD 3/8"-16 X 1"
- 2 – NUT, NYLOCK 3/8"-16
- 2 – 3/8" FLAT WASHER
- 1 – BOLT, BUTTONHEAD 5/16"-18 X 1"
- 1 – 5/16 FLAT WASHER

## Application(s) >

HARLEY  
DRESSER 1997-2008

## Instruction Manual >

601-2202

Page 1 of 1

### Read all instructions carefully before installing your new Cobra® product!

1. Remove any accessories that may prohibit the installation of your new freeway bar.
2. Carefully rotate the freeway bar into position between the frame down-tubes and front tire. NOTE: Make sure not to capture or pinch the clutch cable with the freeway bar. Align the holes in the freeway bar's lower mounts with the open holes on the floorboard frame mounts. Position the freeway bar's upper mount behind the down-tube frame brace and align the holes.
3. Insert the (2) supplied 3/8"-16 x 1" buttonhead bolts thru the freeway bar's lower mounts and floorboard frame mounts; secure with supplied 3/8" flat washers and nylock nuts. See Diagrams. **DO NOT FULLY TIGHTEN.**
4. Insert the supplied 5/16"-18 x 1" buttonhead bolt (with supplied washer) thru down-tube frame brace and thread into the freeway bar's upper mount.
5. Make sure freeway bar is aligned properly then fully tighten the 5/16-18" bolt followed by the 3/8"-16 bolts and nuts.

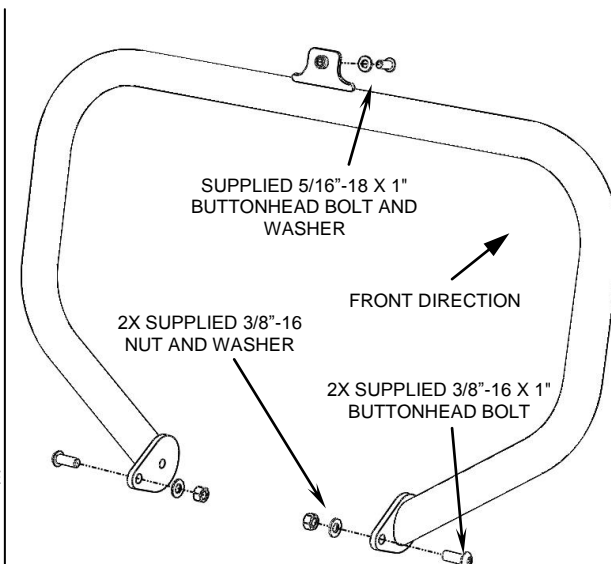
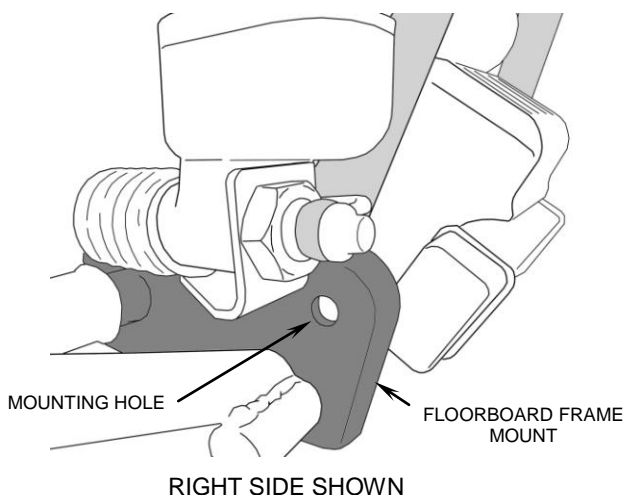

**Cobra Freeway Bars add style to your motorcycle. They are not designed to withstand a serious impact and may not protect you and/or your motorcycle in the event of a crash.**

**\*Cobra® recommends you always wear a helmet while riding. Please never operate your motorcycle while under the influence of alcohol and/or drugs. Enjoy the new look of your motorcycle and please ride safely.**